

# Powerful 1100 W Air Motor Long Life Motor Vanes Low Compact Angle Head



## Features

- Motor power increased by 157%, yet air consumption reduced by 20% (Compared with Model MAG-50)
- Long life motor vanes reduce tool downtime
- Low compact angle head for better accessibility
- Vibration damped Side Handle
- Locking Spindle - for quick disc change

## Applications

Deburring, cleaning and smoothing applications at fabrication shops, foundries, refineries, shipyards, power plants and a variety of other industries



# Pneumatic Angle Grinder

# MYTON

## Model MLG-50

for 5" Depressed Center Wheel



Low Compact Angle Head

Locking Throttle Lever

Vibration Damped Side Handle  
(Can be positioned for left hand  
or right hand operation)

Push Button  
Locking Spindle

### Specifications

Model		MLG-50
Rated Air Pressure	MPa (kgf/cm <sup>2</sup> )	0.6 (6)
Air Consumption	m <sup>3</sup> /min	0.7
Free Speed	min <sup>-1</sup>	11000
Depressed Center Grinding Wheel	mm (inch)	125 (5)
Hose Size	inch	3/8
Mass (Weight)	kg	2.5

### Dimensions

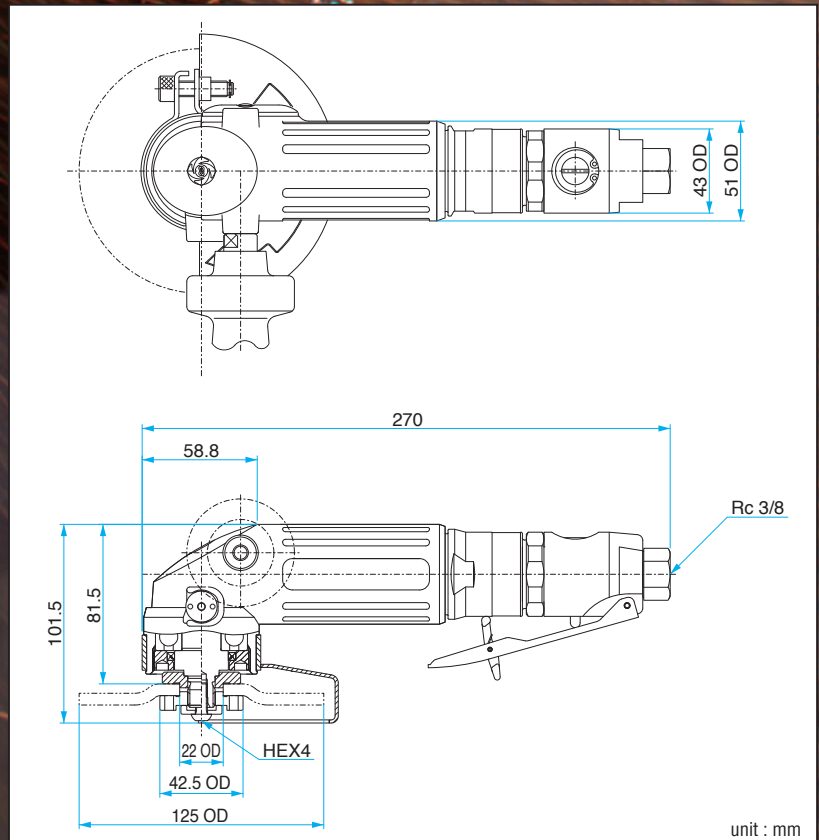

### Accessories Included

Handle Ass'y	1 set
Wheel Guard Ass'y	1 set
Hex. Socket Screw Key 6	1 pc.
Hex. Socket Screw Key 4	1 pc.
Pin Face Wrench	1 pc.
Bushing R 3/8 × NPT 3/8	1 pc.



#### Head Office

9-4, Nakaikagami 2-chome, Ohta-ku, Tokyo 146-8555 Japan  
Tel : +81-3-3755-1111 Fax : +81-3-3753-8791  
E-mail : overseas@nitto-kohki.co.jp

DISTRIBUTED BY

This catalog is printed using environmentally friendly paper and vegetable oil inks.

